

# A Novel Platform to Control Biofouling in Pearl Oysters Cultivation

Van-Nhan Tran<sup>1</sup>, Quan-Dung Pham<sup>1</sup>, Tan-Sang Ha<sup>2</sup>, Yue Him Wong<sup>3</sup>, and Sai-Kit Yeung<sup>1,2</sup>

**Abstract**—This paper presents a simple yet effective design of a platform to automate the task of shellfish aquaculture, specifically pearl oysters. Compared to traditional methods, our platform can eliminate the tedious task of cleaning the pearl oysters due to fouling. Inspired by the low and high tide characteristics of the intertidal zone, our platform employs an air-water displacement mechanism to periodically float pearl oysters above the water's surface, exposing fouling organisms to air and sunlight. While pearl oysters have developed the ability to stay alive during low tide, these fouling organisms cannot survive after prolonged exposure, thus preventing them from developing. Additionally, the platform provides an alternative approach to grow not only pearl oysters but also various types of shellfish, consequently benefiting the aquaculture industry. We introduce the design of the platform and provide a comprehensive analysis. We also demonstrate the practical deployment of the platform for cultivating pearl oysters.

## I. INTRODUCTION

A recent study indicates that seafood shows potential for meeting nutritional needs while having a less adverse impact on the environment [1]. Among all types of seafood, bivalves such as mussels and oysters are able to achieve the highest nutrient benefit at the lowest greenhouse gas emissions. Due to the numerous advantages of seafood, its demand has increased significantly [2]. To produce sufficient seafood for an increasing population, large-scale fish farms become essential [3]. Nevertheless, manual cultivation is laborious, making it inadequate to meet demand. Recently, automated cultivation systems have achieved a considerable increase in productivity and, consequently, economic return.

However, automated shellfish aquaculture has witnessed a major issue in biofouling where the target culture species are exposed to fouling organisms (Fig. 1). This results in physical damage, mechanical interference, biological competition, and environmental modification to the shellfish [4], [5]. According to [4] biofouling control, which remains one of the most difficult challenges in the aquaculture industry, attributes an estimate of 5–10% of production costs.

In shellfish aquaculture, biofouling control falls into five categories: (1) avoidance of natural recruitment to prevent settlement and growth of biofouling; (2) physical removal ranging from scrubbing and brushing to chemical dips and sprays; (3) biocontrol using natural species; (4) coatings



Fig. 1. Fouling issue in aquaculture.

on shells; (5) control and protection for equipment using antifouling coatings and organic biocides [4]. Among these approaches, physical removal and coatings are the most common. Shellfish farmers use power washing equipment to discard fouling organisms attached to the shells of the cultured species and the nets or cages. Pearl oysters tend to get stressed or shocked after cleaning, and thus they need to be manually cleaned with knives, and brushes in a gentle way [4], [6]. Biological control is solely used in small-scale shellfish aquaculture where modification of culture techniques is required. A few biodegradable coatings were found to be successful in protecting the pearl oysters from fouling, though they are unsuitable for long-term antifouling control [7]. In recent years, new antifoulant coatings are being developed, which is able to prevent biofouling with years of lifespan [8]. Antifouling paintings consisting of biocidal compounds such as heavy metals and organic biocides are used to protect the culturing equipment; however many of the chemicals and heavy metals involved are recognized as dangerous in the environment, with detrimental effects on the survival and growth of shellfish [9].

One of the methods in nature that can prevent fouling takes place at the intertidal zone. Species living in this region as barnacles are submerged with water during high tide and exposed to the air during low tide. Intertidal zone species have developed the ability to survive during low tide. In contrast, fouling organism will be killed after being exposed for a short period of time. Due to this special characteristics, intertidal zone species are essentially free of fouling.

<sup>1</sup>Division of Integrative Systems and Design, School of Engineering, Hong Kong University of Science and Technology, Clear Water Bay, Hong Kong SAR vntran@connect.ust.hk, qdpham@connect.ust.hk

<sup>2</sup>Department of Computer Science and Engineering, School of Engineering, Hong Kong University of Science and Technology, Clear Water Bay, Hong Kong SAR tsha@connect.ust.hk, saikit@ust.hk

<sup>3</sup>Institute for Advanced Study, Shenzhen University, Nanshan District, Shenzhen, Guangdong, China timwong@szu.edu.cn

This work focuses on solving the biofouling issue in shellfish aquaculture specifically pearl oysters. Inspired by the characteristics of the intertidal zone, we develop a platform that can be used to grow pearl oysters while simultaneously eliminating fouling. By utilizing air-water displacement mechanism, we could make the pearl oysters float and sink that is similar to the low and high tide behaviors. We also equip the platform with monitoring capability by recording images of the pearl oysters and temperature sensor values. We demonstrate the platform's working principles and functionalities through field test. Our platform can be extended to cultivate different varieties of shellfish such as clams, mussels, scallops, goose barnacles, etc. The 3D model of our platform is shown in Fig. 2

The contributions of this work are as follows:

1) To the best of our knowledge, this is the first automated platform to cultivate pearl oysters with monitoring capability. It eliminates the fouling issue by periodically floating the pearl oysters above the water surface, and thus no longer requiring repetitive cleaning as traditional culturing methods.

2) A collection of data comprises images of pearl oysters and environment sensor readings during the cultivation process. This dataset can serve two purposes. Firstly, the images of pearl oysters are valuable in determining their growth process by utilizing computer vision techniques. The segmentation algorithm can be employed to recognize the boundary of the pearl oysters' shells, which enables the monitoring of their growth. The anomaly detection algorithm can identify irregular spots on the pearl oysters' shells allowing for early disease prediction and prevention. Secondly, environment sensor measurements such as air temperature, humidity provide an effective indication for adaptive adjustment of the platform's control algorithm.

3) Although we tested the platform's working principles on pearl oysters, our platform's design is versatile enough to accommodate the cultivation of various bivalve species, including clams, mussels, scallops, goose barnacles, etc.

The rest of this paper is organized as follows. In Sec-

tion II, we introduce the overall system design. In Section III, the mechanical design and analysis are presented. The experimental evaluation is provided in Section IV. Finally, conclusions are given in Section V.

## II. OVERALL SYSTEM DESIGN

### A. Air-water displacement mechanism

Our platform relies on the air-water displacement mechanism to generate the buoyant force. As shown in Fig. 3, the platform comprises three main components: the linear guide, the air-water tank, and the sandwich net. Each linear guide composes of a couple of linear plastic bearings and a carbon fiber rod. The air-water tank is a cylinder with two cutouts, one at the top and the other at the bottom, both acting either as an inlet or outlet. The top cutout is connected to the high-pressure air source generated by an electric air pump. The bottom cutout is simply a hole to let water flow in and out of the tank. The sandwich net, where the pearl oysters are inserted during the cultivation period, is placed on top of the air-water tank. The working principle of our platform is as follows. Initially, the net with inserted pearl oysters sinks as soon as water fills the tank via the bottom cutout (Fig. 3a). As pumping air into the tank via the top cutout, water residing inside the tank is pushed outside via the bottom cutout since air has a much lower density compared to water (Fig. 3b). The air starts to fill up the tank's volume resulting in reduce its weight at the same time. As a consequence of that, this turns the platform into a positive buoyancy system that lifts the net upward. Finally, the net is lifted up to its highest level, i.e. above the waterline, exposing the pearl oysters to the air and sunlight (Fig. 3c). We will further discuss the mechanical design in detail in the next section.

### B. Electronics system

This section provides an overview of the electronics system that realizes the platform's floating and sinking behavior. The system composes of three main units, as shown in Fig. 4. The whole system relies on the power unit which

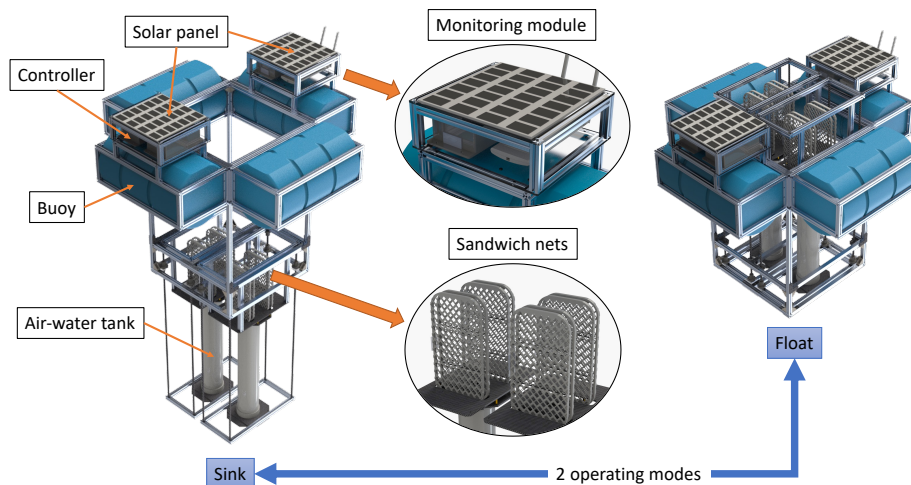

Fig. 2. The 3D model of the platform.

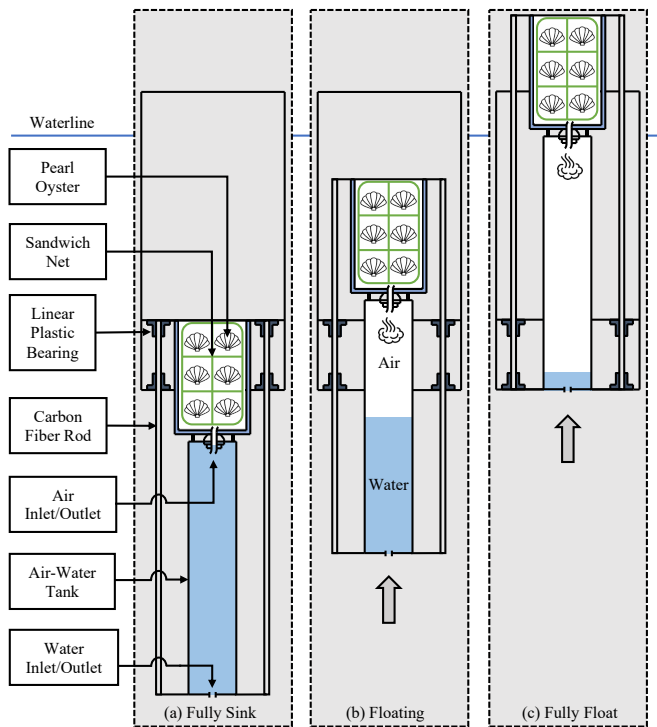

Fig. 3. Diagram of the proposed air-water displacement mechanism. (a) When the net fully sinks, the pearl oysters are below the waterline. (b) The net is floating up due to the buoyant force. (c) When the net fully floats above the waterline, the pearl oysters are exposed to the air and sunlight.

provides the power source. Solar panels are used to generate energy for the platform in an effort to make it a sustainable device. We employ Lithium-ion batteries to store the power allowing the platform to function for several days even in poor sunlight conditions. The processing unit is responsible for two main tasks. The first task is to send the control signal to the actuation unit to perform the float and sink actions. The second task is to acquire data to monitor the growing process including capturing the images of pearl oysters and collecting sensor information such as water temperature. We will delve deeper into the monitoring module in the subsequent section. The actuation unit consists of an electric air pump, a solenoid valve, and the relays. The electric air pump, the solenoid valve, and the air-water tank share the same pneumatic pipeline. They work together to direct air from the atmosphere to the tank or vice versa. When the air pump is turned on and the solenoid valve is turned off simultaneously, the air pumps into the tank which makes the nets float. After the nets are completely above water level, the air pump is turned off to save power. The nets are then kept floating for a predetermined duration until the valve is turned on. As soon as the valve is turned on, air from the tank is pushed into the atmosphere via the exhaust port of the valve. Soon after, the tank will be filled with water and the nets will sink subsequently.

Photos are taken from the side of the platform using a camera controlled by a single-board computer (SBC) to monitor the growth of pearl oysters as illustrated in Fig. 5. Due to

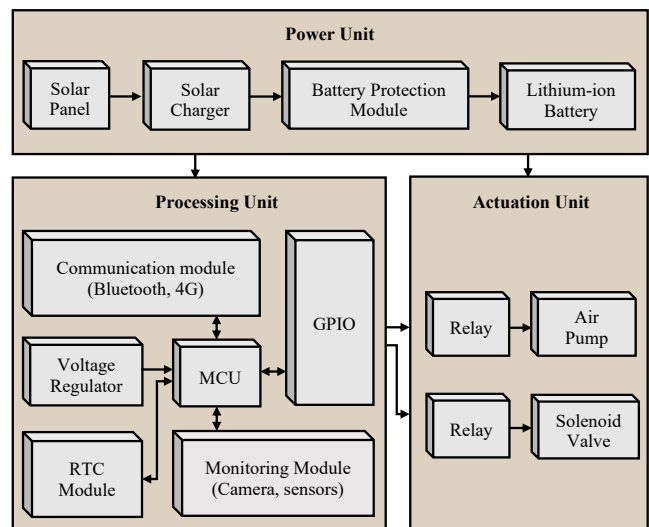

Fig. 4. Electronics system diagram.

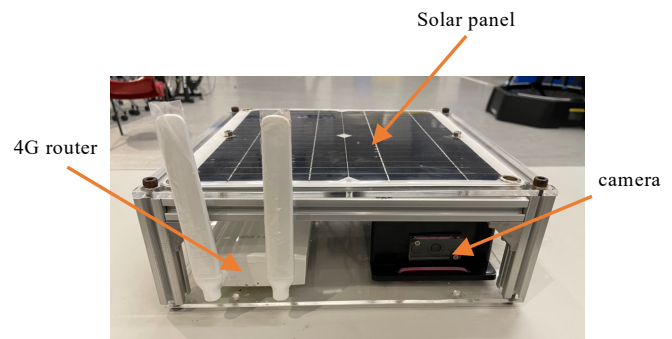

Fig. 5. Monitoring module setup.

the high energy consumption of this computational device, the battery drains quickly, causing the module and other actuators to become unreliable. In addition, we observe that real-time monitoring of pearl oyster growth is unnecessary. Thus, in order to reduce energy consumption, we solely turn on the minicomputer during the predefined capture intervals. A power-efficient microcontroller unit (MCU) is utilized to determine when to turn on the SBC with the assistance of the real-time clock (RTC) module. The 4G router provides the internet connection to upload the photos to our server once they are taken. Similar to the SBC, the router is powered on at specified intervals and prior to the SBC to ensure a successful connection with the mobile service provider. The entire capturing process only takes 10 minutes to complete.

Furthermore, the monitoring module includes a DS18B20 temperature sensor. Even though pearl oysters are exposed to air and sunlight for a period of time to effectively remove fouling, if they are subjected to high temperatures for too long, they may experience heat shock. In order to avoid this, the temperature readings are utilized to determine the platform's starting time and duration. If the temperature is not ideal, the length of floating is shortened accordingly.

### C. Auxiliary Design Feature

Several features of the platform are designed to endure harsh conditions in marine environments. A major concern is how to make the platform durable for a long period of time, e.g. 3–6 months. The linear guide is among the most vulnerable parts of the mechanism. We select carbon fiber rods and linear plastic bearings mainly because they are corrosion free while strong enough to support the moving parts. We use aluminum extrusions to construct the frame of the platform for some benefits. They are corrosion resistant, easy to assemble, and strong while being lightweight. All connectors, such as the corner brackets, nuts, and bolts, are grade 316 stainless steel which is frequently used in seawater. Besides the corrosion issue, we also need to ensure that the controller box is waterproof. The electronic components are placed inside a plastic container with proper sealing. Most components are widely available and relatively low-cost, which reduces the total cost of the platform and makes it more accessible to shellfish farmers.

We also create a new type of net inspired by the sandwich structure. It consists of two plastic frames connected by a hinge. The frames are wrapped around using nylon mesh. To prevent the pearl oysters from overlapping, we divide the net into smaller compartments. All selected components are corrosion resistant and UV resistant to endure marine conditions and sunlight. An example of the sandwich net is shown in the experiment section.

## III. MECHANICAL DESIGN AND ANALYSIS

This section provides a detailed mechanical analysis of our platform, including the waterline identification method, the air pressure calculation, the static stability analysis, and other auxiliary design features.

### A. Waterline Identification

Since the working principle of our platform mimics the dry and wet characteristics of the intertidal zone, it is crucial to identify the waterline where the pearl oysters float above water. Without knowing the waterline position during the design process, it is difficult to ensure that the pearl oysters are completely exposed to the air and sunlight. In this part, we explain how we determine the waterline of the proposed platform by constructing a design study as follows. We create two configurations where the first has all components with their default materials and the other with water selected as materials for all components. The water configuration is necessary since we will use it to simulate the displaced volume of water which equals the weight of the platform in the default configuration. We then add an extruded cut from the top of the platform using a rectangle with varying heights. This height essentially indicates the distance from the waterline to a predefined reference. We could manually adjust the height in a brute-force setting until the weight of the water configuration after cutting matches that of the default configuration. However, we could automate this procedure based on certain parameters. We solely need to specify the range of the height, the step

between two consecutive scenarios, and the constraint which is the weight of the platform in the default configuration. We run the design study several times to fine-tune the range and step appropriately. Once the matched scenario is found, it represents the position of the waterline, as in Fig. 6.

### B. Air Pressure Calculation

In this section, we present the method for determining the air pressure required to adequately pump water from the air-water tank.

Assuming that air pressure output from the air pump is approximately the same as air pressure at the air inlet, i.e. the pressure along the pneumatic pipeline remains constant. Let  $P_1$  denote the air pressure at the air inlet and  $P_2$  denote the air pressure at the water outlet (Fig. 7). Based on the aforementioned assumption,  $P_1 = P_{air\_pump}$ , we formulate the relationship between  $P_1$  and  $P_2$  using Bernoulli's equation [10] as follows:

$$\frac{P_1}{\rho g} + \frac{v_1^2}{2g} + z_1 = \frac{P_2}{\rho g} + \frac{v_2^2}{2g} + z_2 \quad (1)$$

where  $\rho$ ,  $g$ ,  $v_1$ ,  $v_2$ ,  $z_1$ , and  $z_2$  are the seawater density, gravitational acceleration, water velocity at the inlet, water velocity at the outlet, the height of the inlet, the height of the outlet, respectively.

Let  $z_2$  be the reference ( $z_2 = 0$ ). It is assumed that the water velocity at the inlet is very low ( $v_1 \approx 0$  m/s). According to hydrostatic pressure formula [11],  $P_2$  can be computed as:

$$P_2 = \rho g(l_a + l_b) \quad (2)$$

where  $l_a$  is the length from the waterline to the air inlet,  $l_b$  is the length of the air-water tank.

From (2) and (1), we obtain:

$$P_1 = \frac{\rho}{2}v_2^2 + \rho g l_a \quad (3)$$

$l_a$  can be determined after identifying the waterline in the previous section. Here we choose a small value of  $v_2$  ( $v_2 = 0.1$  m/s) to indicate that water is pushed outside successfully. The air pump will need to provide at least pressure  $P_1$  calculated from (3) to sufficiently push water out of the tank.

### C. Static Stability Analysis

Concerning exist regarding the platform's ability to endure strong wave action caused by adverse weather, the static stability curve ( $GZ$  curve) describes the platform's resistance to capsizing. Given the static stability curve, we can determine the heel angle's safe operating range. Fig. 8 shows the diagram to calculate  $GZ$  while Fig. 9 illustrates the static stability curve of the platform while floating. The relationship between  $GZ$  and the heel angle can be formulated as follows,

$$GZ = GB' \times \cos \left( \phi + \sin^{-1} \left( \frac{XB'}{GB'} \right) \right) \quad (4)$$

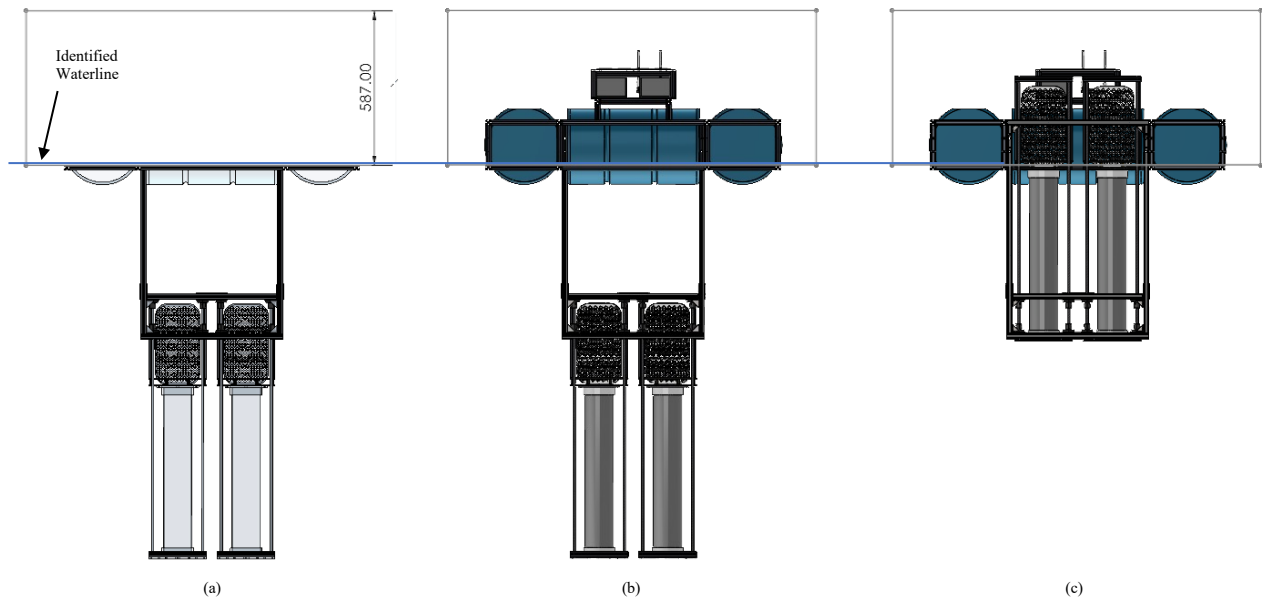

Fig. 6. Waterline identification design study result. (a) The platform in its water configuration with extruded cut applied from the top to the identified waterline. (b) The relative position of the identified waterline to the platform in its default configuration. (c) The relative position of the identified waterline to the nets when they are floating. It can be verified that the pearl oysters will be completely exposed to air and sunlight.

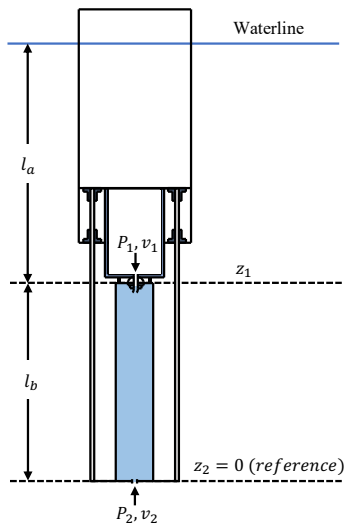

Fig. 7. Air pressure diagram.

where  $G$ ,  $B'$ ,  $M$ ,  $GZ$ , and  $\phi$  are the center of gravity, center of buoyancy, metacentre, righting arm, and heel angle, respectively.

To obtain the  $GZ$  curve, we conduct multiple design studies as described in the previous section. At each step of  $\phi$ , we identify the corresponding waterline position. Based on the current position of the waterline, we can determine the center of buoyancy  $B'$ . Since the center of gravity  $G$  is fixed, the values of  $GB'$  and  $XB'$  can be computed accordingly. Fig. 9 shows the results where a step of  $5^\circ$  is selected. The curve reveals that the range of stability is from  $0^\circ$  up to  $83^\circ$ . The platform will capsize if it goes beyond this range. It encounters the maximum righting arm  $GZ$  at  $25^\circ$ . Based on

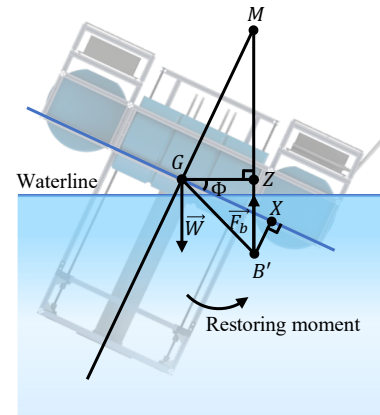

Fig. 8. Static stability analysis diagram.

this analysis, our platform can endure strong wave action.

#### IV. EXPERIMENTAL EVALUATION

A prototype of the platform is built as shown in Fig. 11. We conduct multiple experiments to evaluate the working principle of our platform and demonstrate its functionalities in cultivating pearl oysters. Table I presents the specifications of the prototype. According to [12], the optimum temperature of air exposure for pearl oysters is determined at  $25^\circ\text{C}$ , and the maximum tolerable time is no more than 9 hours (with a survival rate  $> 95\%$ ). The time of testing the platform is summer so the temperature is relatively high. To prevent heat shock to the pearl oysters, we set the float duration to only 2 hours. The float duration heavily depend on the season and the air temperature. The current design can insert up to 10 sandwich nets, with 6 pearl oysters per net (Fig. 10),

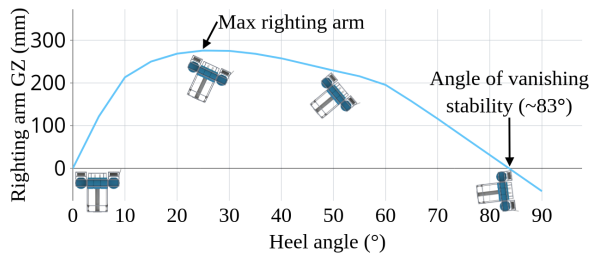

Fig. 9. Static stability curve of the platform.

TABLE I  
SPECIFICATIONS OF THE PLATFORM

Parameters	Values
Dimensions ( <i>Length</i> × <i>Width</i> × <i>Height</i> )	1130 × 1130 × 1860 (mm)
Weight (without pearl oysters)	40 kg
Number of nets	up to 10
Number of pearl oysters per net	6
Time it takes to float	1 minute
Time it takes to sink	4 minutes
Float duration	2 hours (can be changed)
Depth range	526 – 834 mm

which results in 60 pearl oysters in total. For the purpose of testing, we used 4 nets only. To measure the floating and sinking time, we test multiple times and take the average. The pearl oysters inserted into the nets could reach up to 834 mm depth when sinking.

We perform multiple tests to verify the platform’s working principle. The platform can successfully float and sink the pearl oysters, as illustrated in Fig. 11c–d. When the nets float, the pearl oysters are completely above the water’s surface, allowing them to dry.

Since the platform’s development is still in the early stage, there are some shortcomings. The current depth range is relatively limited. In fact, pearl oysters will grow faster when submerged deeper, e.g. 1–2 meters. Another weakness is related to the ease of deployment. In the current design, after the pearl oysters are inserted into the nets, we have to tie them manually to the main body frame to prevent the nets from shaking. It will be more convenient if there is a self-locking mechanism that fixes the nets in place.

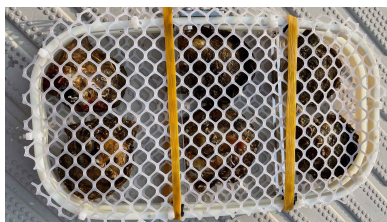

Fig. 10. Pearl oysters inserted into our sandwich net design. Each net can accommodate up to 6 pearl oysters.

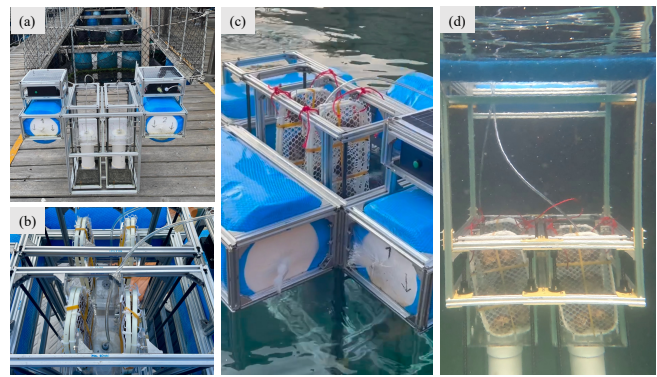

Fig. 11. Testing and deployment of our platform. (a) Deployment of the platform in Lamma island fish farm. (b) The pearl oyster nets are inserted into the platform. (c) The pearl oysters while floating. (d) The pearl oysters while being submerged underwater.

## V. CONCLUSIONS AND FUTURE WORK

This paper describes the design of a novel platform with biofouling control and monitoring capabilities for the cultivation of pearl oysters. By imitating the characteristics of the intertidal zone, the platform is able to remove fouling automatically, which results in eliminating the need for repetitive labor work compared to traditional cultivation methods. In this study, we present the design and analysis of the mechanism. We also address challenges and propose certain design features that are optimal for marine environments. Although the current design still has some shortcomings such as limited depth range and inconvenience in deployment, we strongly believe that the platform will benefit shellfish farmers and the aquaculture industry.

In the future, it is necessary to improve the design as well as add functionalities to the platform. We plan to investigate how to scale up the platform. Increasing the number of pearl oysters that can be cultivated is crucial in commercializing the platform. Although we only tested on pearl oysters, the platform can also be used for various types of shellfish such as clams, mussels, scallops, goose barnacles, etc. This would bring us closer to our long-term goal of solving sustainable food source issues. Another interesting future direction is understanding the data that we collected, including images of pearl oysters and temperature sensor measurements. Computer vision techniques such as segmentation and anomaly detection would be useful to monitor the growth of pearl oysters. We could also add more sensors such as the salinity sensor to study its effect on the growth of pearl oysters. Last but not least, we could build a website to display these sensor data in order to aid the monitoring process.

## ACKNOWLEDGMENT

This research project is partially supported by an internal grant from HKUST (R9429), the Innovation and Technology Support Programme of the Innovation and Technology Fund (Ref: ITS/200/20FP) and the Innovation Team Project of Universities in Guangdong Province (No. 2020KCXTD023).

## REFERENCES

- [1] M. Bianchi, E. Hallström, R. W. Parker, K. Mifflin, P. Tyedmers, and F. Ziegler, "Assessing seafood nutritional diversity together with climate impacts informs more comprehensive dietary advice," *Communications Earth & Environment*, vol. 3, no. 1, pp. 1–12, 2022.
- [2] F. FAO *et al.*, "The future of food and agriculture—trends and challenges," *Annual Report*, vol. 296, pp. 1–180, 2017.
- [3] G. Viatte, "Adopting technologies for sustainable farming systems: an oecd perspective," in *Adoption of Technologies for Sustainable Farming Systems Wageningen Workshop Proceedings*, 2001, p. 14.
- [4] I. Fitridge, T. Dempster, J. Guenther, and R. De Nys, "The impact and control of biofouling in marine aquaculture: a review," *Biofouling*, vol. 28, no. 7, pp. 649–669, 2012.
- [5] J. Bannister, M. Sievers, F. Bush, and N. Bloecher, "Biofouling in marine aquaculture: a review of recent research and developments," *Biofouling*, vol. 35, no. 6, pp. 631–648, 2019.
- [6] M. Haws, *The basic methods of pearl farming: a layman's manual*. Citeseer, 2002.
- [7] R. De Nys and O. Ison, "Evaluation of antifouling products developed for the Australian pearl industry," *Fisheries Research and Development Corporation*, 2004.
- [8] J. E. Gittens, T. J. Smith, R. Suleiman, and R. Akid, "Current and emerging environmentally-friendly systems for fouling control in the marine environment," *Biotechnology advances*, vol. 31, no. 8, pp. 1738–1753, 2013.
- [9] J. Paul and I. Davies, "Effects of copper-and tin-based anti-fouling compounds on the growth of scallops (*pecten maximus*) and oysters (*crassostrea gigas*)," *Aquaculture*, vol. 54, no. 3, pp. 191–203, 1986.
- [10] D. Bernoulli, "Hydrodynamica," *Dulsecker. Consultable en ligne <http://imgbase-scd-ulp.u-strasbg.fr/displayimage.php>*, vol. 1738, 1738.
- [11] B. R. Munson, T. H. Okiishi, W. W. Huebsch, and A. P. Rothmayer, *Fluid mechanics*. Wiley Singapore, 2013.
- [12] Z. Gu, H. Wei, F. Cheng, A. Wang, and C. Liu, "Effects of air exposure time and temperature on physiological energetics and oxidative stress of winged pearl oyster (*pteria penguin*)," *Aquaculture Reports*, vol. 17, p. 100384, 2020.