

Development of a Compact Collar-Mounted Feeder for Remote Dog Feeding

Kai Fukuzawa¹, Tsige Tadesse Alemayoh², Shotaro Kojima², Ranulfo Bezerra², Miho Nagasawa³,
Takefumi Kikusui³, and Kazunori Ohno²

Abstract—Timely food rewards are crucial for effective dog training, but providing immediate reinforcement is difficult when the handler cannot be near the dog. Existing systems, such as stationary feeders, restrict the dog’s movement and cannot deliver rewards flexibly. Our previous back-mounted feeder (1.2 kg) enabled successful remote food delivery, but its size and weight meant it could only be used for medium- to large-sized dogs. Remotely controlled food-dispensing devices solve this by allowing spatially unconstrained rewards without limiting the dog’s movement. However, for real-world use, such devices must be compact, lightweight, and unobtrusive to avoid disrupting natural behavior or requiring long habituation periods.

Hence, in this study, we present the development and validation of a collar-mounted feeder (hereafter, “collar-feeder”) capable of remotely dispensing food multiple times. The newly developed collar-feeder weighs only 143.6 g and can store up to 20 food items. A compact internal design with fewer electronic parts reduces its size and weight. Experiments showed a 100% feeding success rate among dogs unbothered by the device, while some dogs mistook it for a toy. These findings highlight the potential applicability of the collar-feeder in dog training and behavioral discipline. With further functional improvement, the collar-feeder presented in this paper may gain widespread adoption. For instance, by integrating biometric sensors and a food-tracking system, the device could serve as a valuable tool in households and veterinary clinics for pet health monitoring and management.

I. INTRODUCTION

The bond between humans and dogs has long been shaped by behavioral interactions, with food playing a central role in establishing trust and companionship. Anthropological evidence suggests that food sharing was a pivotal factor in the early domestication of dogs, helping to turn wild canines into cooperative partners [1]. Over time, this practice evolved beyond survival and became a cornerstone in dog training and behavior reinforcement. Today, positive reinforcement methods, especially those using food as a reward, are widely recognized as more effective than punishment-based training strategies [2]. Studies further show that food rewards are often more motivating for dogs than toys [3], highlighting feeding as a key component in dog learning and human-dog communication.

As a result of millennia of domestication, dogs are now integral to human society, assisting in tasks such as drug detection, disease diagnosis, and search and rescue operations. However, in many situations, owners or handlers may



Fig. 1. A dog wearing the collar-feeder

be physically distant from their dogs—whether due to daily routines, travel, or the operational nature of working dogs. To help maintain interaction and ensure timely feeding, a variety of smart feeders have recently emerged on the market [4]. These devices allow remote-controlled food dispensing, often combined with audio or video capabilities, enabling owners to interact with their pets even when away from home [5][6]. However, most commercially available products are stationary, designed to remain fixed in one location. This limits their use to controlled environments and can restrict a dog’s natural movement.

Therefore, a portable feeding system that is independent of installation location is needed. A remote feeder capable of delivering immediate reinforcement regardless of location is essential, as timely reward delivery is especially critical in dog training, particularly for working dogs such as search and rescue dogs, who often operate at a distance from their handlers. Research shows that even a one-second delay in delivering a reward can significantly impair learning efficiency [7][8]. To achieve this, a body-mounted feeder that moves with the dog is a promising approach. For such a system, compactness and lightweight design are critical to avoid interfering with the dog’s natural behavior, especially during dynamic movements in demanding environments.

In this study, we designed and developed a small, lightweight, remote-controlled feeder that attaches to a collar—a form familiar to dogs—allowing use without prior habituation. Fig 1 shows a dog wearing the developed feeder. The developed collar-feeder is spherical with a diameter of 74 mm and weight of only 143.6 g. Despite its compactness, the device stores more than 20 pieces of food and reliably

¹Kai Fukuzawa is a graduate student with the Graduate School of Information Sciences, Tohoku University, Japan
fukuzawa.kai@tr.is.tohoku.ac.jp

²Tough Cyber Physical AI Research Center, Tohoku University, Japan

³Animal Science and Biotechnology, Azabu University, Japan

dispenses it regardless of the dog's motion, enabling reward delivery in various postures and orientations. Evaluation experiments with six dogs verified the feeder's dispensing capability and observed behavioral responses.

The main contribution of this study is the development of a compact and lightweight feeding device with excellent portability. It uses a gimbal mechanism that allows it to adapt to the dog's changing posture, making it easy to use in a variety of environments. By utilizing gravity for food dispensing and eliminating the launching mechanism, the number of electronic components and power consumption were reduced. This simplified the internal structure, significantly reducing both size and weight. In addition, the use of an internal battery eliminates the need for an external power supply, enabling flexible use without restrictions on installation locations. Additionally, its lightweight design allows for use with even small-sized dogs, while the spherical shape enhances safety during operation. This paper presents the device's design and indoor validation, with future work focusing on testing in more dynamic settings.

II. RELATED WORKS

Several devices are available that allow remote feeding of dogs. Furbo [5] and PETLIBRO [6], for example, enable users to communicate with their dogs and feed them while watching through a camera feed. These devices are equipped with dog monitoring features and are effective for enabling remote interaction from outside the home. However, because these devices are placed on the ground, the dog's movement becomes restricted to the area surrounding the device. Moreover, because these devices remain in the same location, dogs may become overly attached to them, potentially altering their natural behavior and reducing their effectiveness as a training tool.

In response to these limitations, we previously developed a back-mounted portable feeder that attaches to the dog's back via a suit [9]. This feeder uses a motor-driven mechanism to propel food forward. Fig. 2 shows the shape and size of the solid food used, which consists of spherical biscuits approximately 13 mm in diameter. These biscuits are chosen for their low-calorie content, making them suitable for training and discipline without causing weight gain, even when fed in relatively large amounts. The same food was also used in this study. The device holds up to 20 pieces of food, and each piece can be launched individually by pressing a button on a wireless joypad. When the device was actually mounted on a dog, it achieved a feeding success rate of over 90%, without the dog becoming fixated on the feeder. However, the back-mounted feeder weighs 1.2 kg in total and is designed primarily for medium-sized dogs and larger. Additionally, it was found that dogs need time to become accustomed to the size and sound of the device when using it. Furthermore, since the food is dispensed from the back, the landing point could be outside the dog's line of sight and becomes unpredictable due to bouncing caused by its high potential energy. As a result, the food may end up in ground cracks or bounce too far away, causing delays

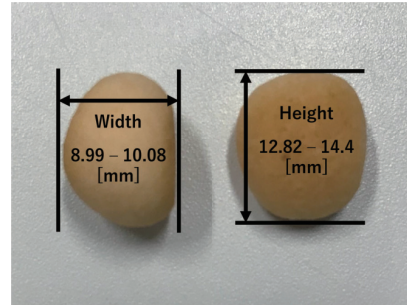

Fig. 2. The shape and size of the solid food used

before the dog can retrieve and eat it. To address these issues, this paper presents the development of a lightweight collar-mounted feeder that dispenses food directly in front of the dog's mouth.

III. DEVELOPMENT OF COLLAR-FEEDER

A. Requirements

In this section, the general requirements for a collar-mounted feeder that is compatible with dogs of various sizes will be discussed. Key design considerations include feeding duration, weight constraints, attachment compatibility, structural safety, and reliable remote dispensing.

One important criterion is the duration for which the collar feeder can continuously supply food. The feeder should store enough food for approximately 5 to 10 minutes of operation, which corresponds to a typical training session for rescue dogs. In this study, it is assumed that food is dispensed every 20 to 30 seconds. Therefore, 20 pieces of food are required to achieve continuous feeding for 5 to 10 minutes.

The second criterion is the weight of the device. To avoid interfering with their natural behavior, the device weight should be less than 5% of the dog's body weight, following the general guideline used in biologging studies [10]. According to McGreevy et al. [11], Chihuahuas, classified as small dogs, have an average body weight of 3.37 kg and were the lightest among all breeds. Therefore, the maximum weight of the device was set to approximately 150 g, equivalent to 5% of 3 kg.

Third, design and fitting are essential considerations. Since dogs are already accustomed to neck-mounted equipment such as leashes, the feeder was designed to attach easily to any standard dog collar. It is anticipated that dogs will not react unusually to the device when it is properly mounted. In addition, the collar-mounted design allows food to be dispensed directly in front of the dog, reducing the delay in delivering rewards.

In line with the aforementioned weight requirements, the device should be compact and safe during vigorous movements. It must also be capable of dispensing food reliably regardless of the dog's posture or motion. As handlers are not always in close proximity to the dog, a remote-controlled dispensing mechanism would enable more efficient training sessions.

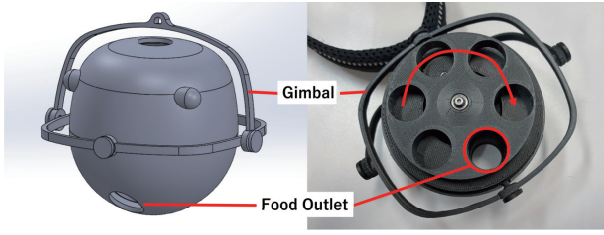

Fig. 3. Overview of the collar feeder (The figure on the right shows the figure on the left with the upper half cover removed.)

B. The developed collar-feeder

1) *overview*: Fig. 3 and Fig. 1 show the developed collar feeder attached to a dog collar and provide an overview of the remote-controlled feeder, respectively. The device features a spherical design with minimal protrusions or sharp edges to ensure safety during movement. It consists of an upper hemisphere housing the food storage compartment and a lower hemisphere containing the electronics. Designed to be compact and lightweight, the feeder weighs only 143.6 g while accommodating up to 20 pieces of food. It is capable of remote operation and is designed to move naturally with the dog, ensuring that feeding does not interfere with the dog's behavior or mobility. It utilizes gravity to dispense food and employs a rotating drum mechanism—similar to those used in capsule toy machines—along with a gimbal system that ensures the outlet consistently faces downward. This design allows the feeder to maintain the same number of food pellets as the back-mounted feeder while eliminating the food launching mechanism, thereby achieving compactness. Additionally, the gimbal mechanism ensures that the outlet always faces downward regardless of the dog's posture, enabling reliable feeding. Furthermore, since the feeder hangs down from the dog's neck, it is positioned close to the ground. This minimizes bouncing and reduces the distance the food travels upon dispensing, allowing the dog to respond more quickly and reliably. The feeder is operated remotely via a Wi-Fi connection using a smartphone, allowing the handler to deliver rewards at precise moments even from a distance.

2) *Mechanism of collar-feeder*: First, the internal structure of the collar-feeder is discussed. Fig. 4 shows the cross-sectional view of the feeder, while Fig. 5 illustrates the layout of the internal electronic components. A microcontroller board, M5StickPlus2 (here after, M5Stick), along with a motor, is installed in the lower hemisphere of the device. The sizes of the M5Stick and the motor to be accommodated in the lower hemisphere are 13 x 48 x 25 [mm] and 12.1 x 22.5 x 24.7 [mm], respectively. The largest component, the M5Stick, was placed at the center, and the motors were arranged in contact with it. Balance between the left and right sides was also considered, and the motor shaft was positioned along the center line. With this arrangement, the point furthest from the center of the hemisphere corresponded to the vertex of the M5Stick or the motor located on the opposite sides of the hemisphere's bottom surface. The distances from the center of the hemisphere to the vertex of the M5Stick and

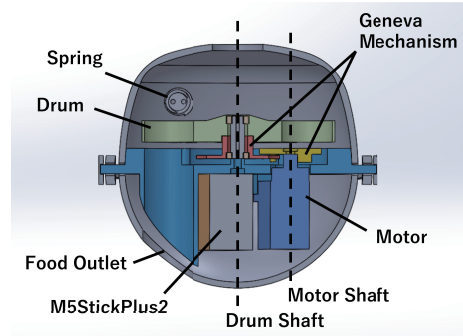

Fig. 4. Cross-section of the collar-feeder

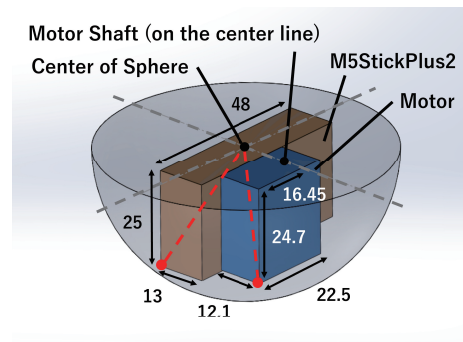

Fig. 5. Device placement in the lower hemisphere (Red dots represent the furthest point candidate.)

to the vertex of the motor were calculated using equations (1) and (2), respectively. Based on these calculations, the minimum required radius of the sphere was determined to be 35.3 mm, and a radius of 37 mm was adopted to allow space for wiring and other considerations.

$$\sqrt{\left(\frac{13}{2}\right)^2 + \left(\frac{48}{2}\right)^2 + 25^2} \approx 35.26 \quad (1)$$

$$\sqrt{\left(\frac{13}{2} + 12.1\right)^2 + 16.45^2 + 24.7^2} \approx 35.02 \quad (2)$$

Next, the food dispense mechanism is discussed. A rotating drum mechanism, commonly used in capsule toy machines, was adopted to transport food to the outlet. This mechanism can hold a large quantity of food and dispenses it one piece at a time. Fig. 3 shows the feeder with its lid removed. The drum has six holes, and the food is packed into the upper hemisphere. By rotating the drum in 60° increments, individual pieces of food are allowed to fall through the outlet.

A spring is placed over the outlet to prevent multiple pieces from being dispensed at once. Additionally, using a flexible spring rather than a rigid one helps to prevent food from getting stuck during dispensing. For power transmission from the motor to the drum, a Geneva mechanism is used, as shown in Fig. 6. Because the axes of the drum and motor are not aligned due to the internal structure of the lower hemisphere, a transmission mechanism is necessary. Since

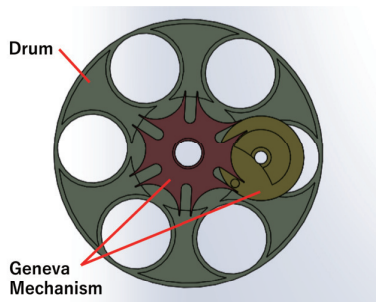

Fig. 6. Geneva mechanism used to transmit power between the motor and drum (The red part and the drum are fixed, and the yellow part and the motor are fixed. When the yellow part rotates one full turn, the drum rotates 60 degrees.)

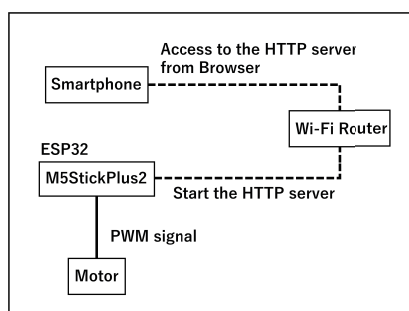

Fig. 7. System configuration of the developed collar-feeder

the motor cannot directly control angular displacement, the Geneva mechanism was selected to convert continuous motor rotation into discrete 60° steps. When the button is pressed, the motor completes approximately one full rotation, causing the drum to advance by 60° , thereby releasing one piece of food.

As the device does not use a forced ejection mechanism, it relies on gravity for food dispense, requiring the food outlet to consistently face downward. To achieve this, a gimbal mechanism—commonly used for camera stabilization—was implemented. Two frames are mounted around the spherical feeder, enabling rotation along two axes and ensuring that the outlet remains downward-facing regardless of the feeder’s orientation.

Lastly, the operation of the feeder is explained. Fig. 7 illustrates the system configuration. The feeder is controlled using the M5Stick, a development board equipped with a microcontroller. The M5Stick includes an ESP32 chip, which provides Wi-Fi and Bluetooth connectivity, as well as a display, physical buttons, and a built-in battery. In this system, the feeder is operated by accessing an HTTP server running on the M5Stick from a smartphone browser. The web interface presents a button, and pressing it triggers the feeder to dispense a single piece of food. The device was designed with lightweight portability in mind and does not require an external battery, relying solely on the M5Stick’s internal power supply (200 mAh @ 3.7 V).

To validate the operation, the feeder was held by hand, filled with 20 pieces of food, and successfully confirmed

to dispense one piece at a time in succession. It was also confirmed that the device could dispense food properly even when shaken by hand. The weight of the feeder alone was 143.6 g, and 192.3 g when combined with the collar. While the device itself satisfies the less-than-150 g requirement, further weight reduction is necessary when considering the total system. According to the 5% rule for biologging [10], the current design is suitable for dogs weighing 3.9 kg or more.

IV. VALIDATION OF THE COLLAR-FEEDER

In this section, we evaluate the performance of the developed collar-feeder by assessing multiple dogs response when fitted with the device and verifying its reliability in dispensing food. All experiments were conducted with the approval of the ethics committees of Tohoku University (Japan) and Azabu University (Japan).

A. Material and methods

The objective is to verify whether dogs can be fed remotely using the developed collar-feeder without being bothered. Six dogs, with their profile shown in Tab. I, were used in the device testing experiment. Each dog is of a different breed, with Dog D and F being noticeably smaller and lighter than the other dogs. The experiment was conducted outdoors on a grassy area for Dog E and F and indoors for the other dogs.

In this validation, we evaluated three aspects: the feeding success rate, the dogs’ behavioral responses, and the time until feeding. The feeding success rate was defined as the ratio of food pieces eaten by the dog to the total number of pieces dispensed. A feeding attempt was considered successful only if the dog ate the food on its own. If a person pointed to the food or called the dog, the attempt was considered a failure. The dog’s response was assessed based on the proportion of time spent performing specific actions during the period the feeder was attached. The feeder attachment time was defined as the duration from when the collar buckle was fastened to when it was removed. Dog behaviors were categorized into three types: “ignore,” “play,” and “other.” “ignore” referred to periods when the dog paid no attention to the device and behaved naturally “play” described times when the dog showed interest by looking at or touching the feeder with its paws. “other” included any behaviors not fitting the above categories. The time until feeding was measured from the moment the food was dispensed to the moment the dog noticed and looked at it.

B. Results

Fig. 8 shows a dog eating food dispensed from the collar-feeder. The food falls straight downward from the outlet, allowing the dog to eat it directly from the ground. It did not bounce or travel far, and the dog was able to consume it immediately at the spot where it landed. Tab. II presents the feeding success rate for each dog, while Fig. 9 illustrates the percentage of each behavioral response relative to the total feeder attachment duration.

TABLE I
DOG INFORMATION

Dog ID	Breed	Sex	Age	Weight [kg]
A	Standard Poodle	female	5	19
B	Standard Poodle	female	5	20
C	Standard Poodle	male	10	22
D	Shetland Sheepdog	female	6	12
E	Labrador Retriever	female	5	22
F	Mix	male	5	9

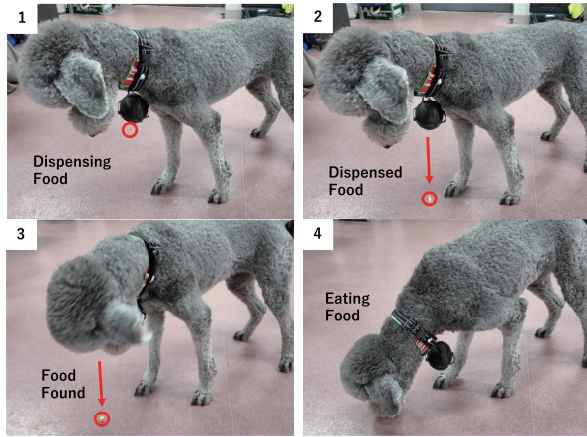

Fig. 8. Feeding a dog using the collar-type feeder

Overall, most dogs were able to feed successfully in the indoor environment, achieving a 100% feeding success rate in 5 out of 8 trials. In contrast, some dogs showed lower success rates during their first trial or in outdoor environments. Behavioral observations revealed individual differences: while some dogs showed little or no interest in the device, others spent nearly half of the session interacting or playing with it.

Five out of 8 trials achieved a 100% feeding success rate. All of these trials were conducted indoors. On the other hand, the success rate was notably low for Dog B (1st time), E, and F, at 38%, 30%, and 0%, respectively. In particular, Dog C did not eat any of the dispensed food, even when its location was pointed out. Dog B's success rate increased from 38% in the first trial to 100% in the second, indicating clear improvement.

In terms of response, Dog A and C recorded 0 seconds in the "play" time, indicating no noticeable behavior suggesting that the dog paid attention to or interacted with the feeder. In contrast, Dog D and F had "ignore" rates of 30.3% and 44.5%, respectively—both below half of the total time. Dog B showed an improvement in feeding success rate on the second trial, but the time spent paying attention to the feeder increased from 6.5% to 27.1%.

In all trials, where the success rate was 100%, it took dogs less than a second to notice the food. For Dog B (1st time) and E, when considering only the successful feeding instances, the average time to notice the food was 0.77 seconds and 0.66 seconds, respectively—both under one second.

TABLE II
FEEDING SUCCESS RATE FOR EACH DOG

Dog ID	Feeding success [pcs.] (success rate)	Average time to notice food [s]
A	10/10 (100%)	0.55 ± 0.09
A (2nd time)	15/15 (100%)	0.84 ± 0.39
B	5/13 (38%)	4.74 ± 11.1
B (2nd time)	15/15 (100%)	0.41 ± 0.17
C	15/15 (100%)	0.32 ± 0.12
D	13/13 (100%)	0.32 ± 0.11
E	3/10 (30%)	6.66 ± 5.85
F	0/10 (0%)	-

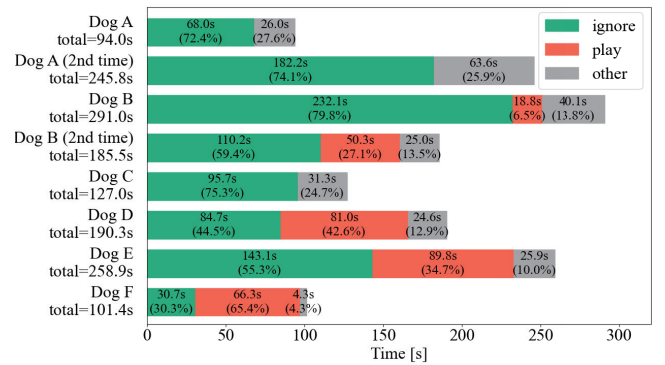

Fig. 9. Percentage of response duration in relative to the total fitting time

V. DISCUSSION

A. Regarding the evaluation experiment

In the evaluation experiment, the developed collar-type feeder worked effectively for most dogs, especially indoors under favorable visibility and acoustic conditions. Most dogs ate the food within one second after dispensing, indicating its potential for rapid, food-based communication and training rewards. Some small or curious dogs tended to play with the device, suggesting room for improvement in the design.

First, the differences in feeding success rates among dogs were mainly attributed to environmental factors. Except for one trial, all indoor trials achieved a 100% success rate, while Dog E and F had 30% and 0% outdoors. This indicates that the feeder is effective for indoor communication and training but presents challenges for outdoor use. Fig. 10 illustrates the difference in food visibility between indoor and outdoor environments. Outdoors, the food blends with the ground and no contact sound is made making it harder for the dogs to notice. In all seven trials where Dog E failed to find the food, it ate it after a person pointed it out, suggesting that making dogs aware of food dispensing could improve outdoor success rates.

Regarding the dogs reactions to the device, most dogs were not bothered by the device, suggesting that a short acclimation period is sufficient. In contrast, smaller dogs, such as Dog D and F, were more curious and tended to treat the feeder as a toy—pushing it with their paws or picking it up with their mouths. This behavior was likely



Fig. 10. Differences in the appearance of food indoors and outdoors

influenced by the spherical design resembling a ball. The feeder's weight for Dog D and F was 1.6% and 2.1% of their body weight, respectively, below the 5% guideline, indicating that weight had a smaller impact than shape or size. In fact, with small dogs, the size and movement of the device may be more noticeable. To accommodate small or highly curious breeds, a design that reduces attention attraction and minimizes movement would be preferable.

Finally, the delay until feeding is discussed. In indoor trials, all dogs noticed the food within one second after dispensing, achieving a 100% feeding success rate. Even Dog B and E, which had lower overall success rates, found the food within 0.77 seconds and 0.66 seconds respectively when successful, indicating that rapid feeding within one second is achievable when dogs detect the food on their own. A previous study has shown that delaying the auditory cue and food reward by only one second reduced task acquisition from 60% to 25% [8]. Based on this, the less-than-one-second delay observed in this experiment suggests that learning efficiency can be maintained for more than a quarter of the dogs. On the other hand, the average time from button press to food dispensing was 1.52 seconds (across 20 trials), resulting in approximately 2.5 seconds from operation to feeding completion—relatively long for associating behavior with reward. One possible solution is to use a secondary reinforcer—such as a sound, light, or odor—that is originally a neutral stimulus but acquires reinforcing properties through pairing with a primary reinforcer like food [13]. For example, by presenting an immediate clicker sound, the dog receives instant feedback that the behavior was correct, and the subsequent food reward strengthens this association, effectively bridging the temporal gap. Moreover, the clicker sound can also serve as an auditory cue indicating food dispensing, particularly useful outdoors where visibility is poor. This function can be implemented using the built-in speaker of the M5Stick integrated into the feeder, requiring no additional hardware. If the sound volume is insufficient, however, an external speaker may be required, introducing a trade-off between device size and weight.

B. Limitation of the collar-feeder

The developed collar-feeder achieved compactness and light weight by reducing components and simplifying its internal structure. However, there is still room for improvement in communication and design.

In terms of communication, the feeder currently connects to a smartphone via a Wi-Fi router, so both must be within

the same network range. By using a smartphone as a mobile hotspot or connecting the feeder to a home router and accessing it via VPN, the distance limitations can be relaxed, enabling remote feeding from outside the home.

In terms of design, the current spherical design leaves unused space in the lower half, suggesting potential to improve volumetric efficiency. For instance, separating the feeding unit from the storage unit and distributing stored food via tubes around the collar could enhance space utilization. Meanwhile, the smooth spherical shape helps reduce the risk of injury. Future work will aim to balance safety and efficient space utilization.

VI. CONCLUSION

In this paper, we designed a small, lightweight, and remote-controlled feeder that can be attached to a collar. It can hold 20 pieces of food while weighing only 143.6 g. In the performance evaluation, the feeder achieved a 100% success rate in 5 out of 8 trials. Notably, 5 out of 6 indoor trials reached 100%, indicating particularly high performance in indoor environments. Dogs' responses varied, with smaller dogs tending to show more interest in the feeder. The fact that some dogs completely ignored the feeder suggests potential applications in dog training and discipline. Furthermore, by expanding the feeder's functionality, it could be widely adopted for general use. For example, by integrating sensors to measure heart rate and respiration, it could serve as a convenient device for monitoring pet health.

ACKNOWLEDGMENT

This work was supported by JST, CREST Grant Number JPMJCR22P2, Japan.

REFERENCES

- [1] M. Lahtinen, et al. "Excess protein enabled dog domestication during severe Ice Age winters," *Scientific Reports*, 11, Article7, 2021.
- [2] N. J. Rooney, et al. "Training methods and owner-dog interactions: Links with dog behaviour and learning ability," *Applied Animal Behaviour Science*, vol.132, Issue.3-4, pp.169–177, 2011.
- [3] X. A. Lazaro, et al. "Efficacy of Edible and Leisure Reinforcers with Domestic Dogs," *Animals*, vol.13, p.3037, 2023.
- [4] Global Market Insights Inc., "Global Smart Pet Feeder Market Report, 2025-2034," 2025.
- [5] Furbo. Furbo pet camera; [cited 2025 July 31]. Available from: <https://furbo.com/jp>.
- [6] PETLIBRO. Automatic feeder; [cited 2025 July 31]. Available from: <https://petlibro.com/collections/automatic-pet-feeder>.
- [7] C. Browne, et al. "Delayed reinforcement - Does it affect learning?," *Journal of Veterinary Behavior: Clinical Applications and Research*, 8(4), e37-e38, 2013.
- [8] C. Browne, et al. "Dog training: Reinforcement timing and owner body language," *Journal of Veterinary Behavior: Clinical Applications and Research*, 9, e17, 2014.
- [9] S. Nezu, et al. "Effectiveness of canine training using suit-mounted feeder," *Advanced Robotics*, vol.38, Issue.14, pp.947–957, 2024.
- [10] R. M. Casper. "Guidelines for the instrumentation of wild birds and mammals," *Animal Behaviour*, vol.78, Issue.6, pp.1477–1483, 2009.
- [11] P. D. McGreevy, et al. "Dog Behavior Co-Varies with Height, Body-weight and Skull Shape," *PLOS ONE* 8(12): e80529, 2013.
- [12] L. C. Feng, et al. "Comparing trainers' reports of clicker use to the use of clickers in applied research studies: methodological differences may explain conflicting results," *Pet Behaviour Science*, 1-18, 2017.
- [13] D. Michael, "The essentials of conditioning and learning," *American Psychological Association*, 2018.